

Telephones

Outdoor Telephone Specifications

GB90 Series

Wt: Housing Only11 lb
 Wt: e/w tel set14 lb

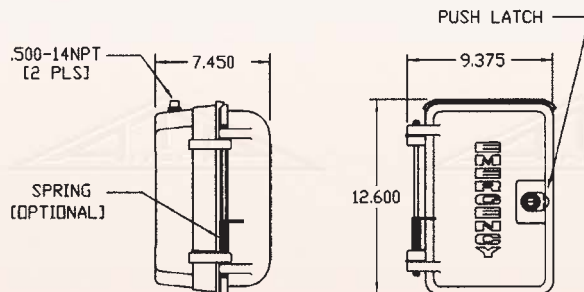

GB59 Series

Wt: Housing Only11 lb
 Wt: e/w tel set14 lb

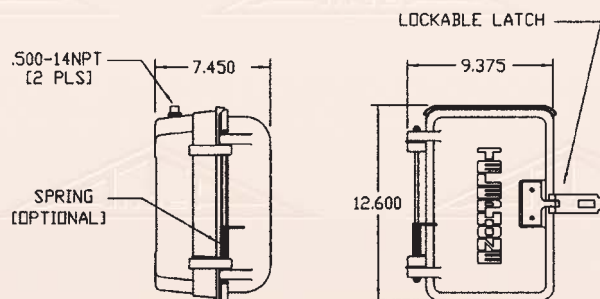

GB70 Series

Wt: Housing Only16 lb
 Wt: e/w tel set20-21 lb

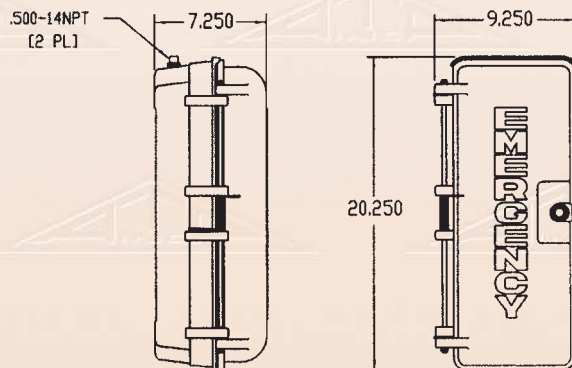

GB32390 Series

Wt:5 lb

